

9770 OVERALL (APPROX)

9000 SHELL

4000 CTRS

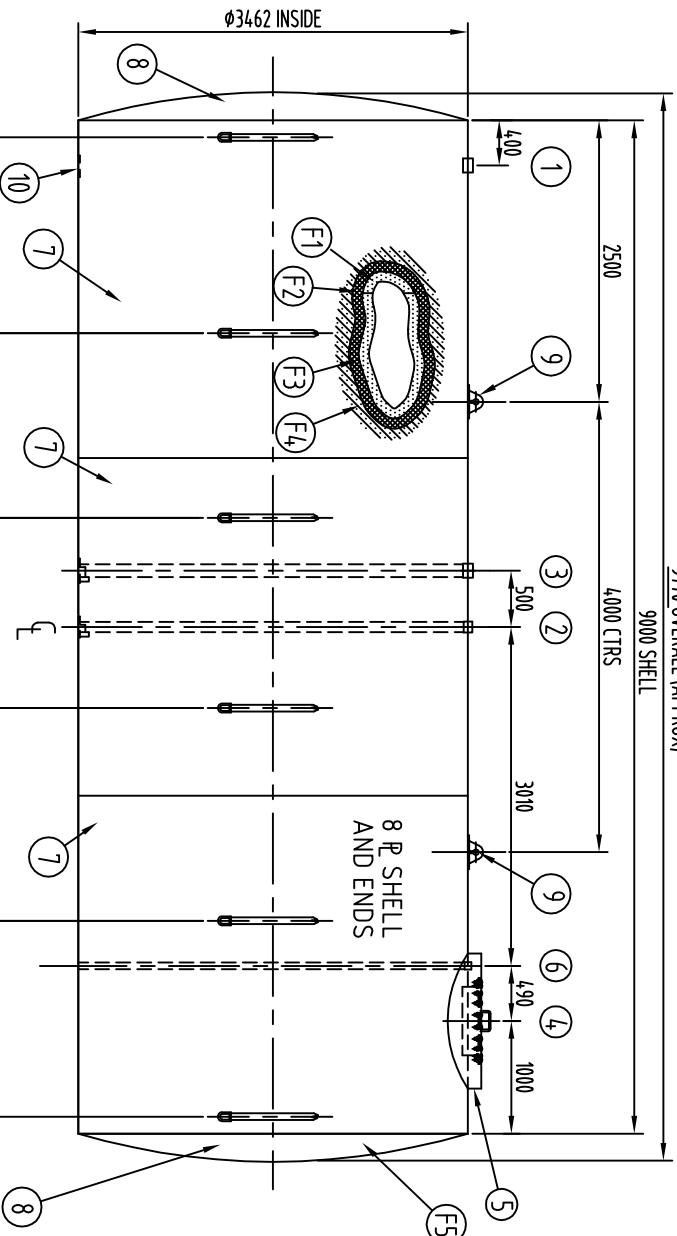

ITEM	DESCRIPTION	WEIGHT
F5	RUST RED FLOWCOAT	-
F4	GLASS OWENN'S CORNINS 360 RR	-
F3	CATALYST	-
F2	AROPOL 7241PS/PW	-
F1	STAND OFF MATERIAL	-

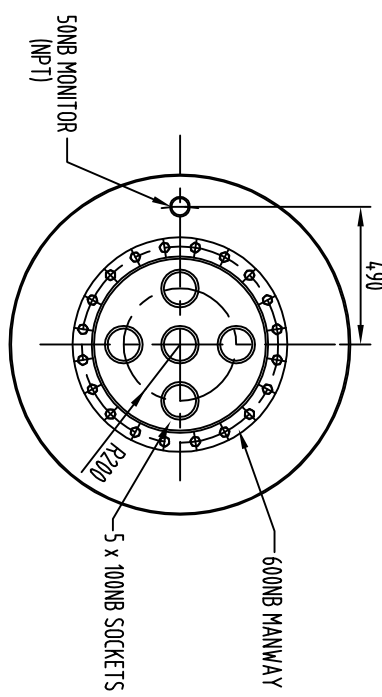

PLAN VIEW ON MANWAY

ITEM	DESCRIPTION	QTY	PART / SUB ASSM No.
S1	HOLD DOWN STRAPS	6	015002
	VACUUM MONITOR GAUGE	1	006137, 017711, 017160
	LIFTING LUG COVERS	2	015071
	DIPSTICK T90	1	SUB1022
	ACCESSORIES		PART / SUB ASSM No.

- NOTE: (S1)
- VACUUM ON INTERSTITIAL SPACE IS FACTORY SET & GAUGE SET
 - INSTALLATION AS PER GLASTEEL II INSTALLATION INSTRUCTIONS & APPLICABLE CODES
 - VESSEL IDENTIFICATION No. & MANUFACTURE DATE ARE LAMINATED TO TOP OF VESSEL
 - VESSEL MANUFACTURED TO AS1692
 - PLASTIC LIFTING LUG COVERS SUPPLIED WITH VESSEL
 - HOLD DOWN STRAPS POSITION ARE TO BE MARKED ON VESSEL DURING MANUFACTURING
 - ALL SOCKETS TO BE CLEANED AND FITTED WITH PLASTIC DUST CAPS
 - 6mm STRIKER PLATES TO BE FITTED UNDER ALL OPENINGS
 - 9: ALL WELDS AS PER AS1554.1-GP (N.D.T. - VISUAL)
 - VOLUME = 90,000 L (APPROX)
 - WEIGHT OF TANK = 8,090 kg (APPROX)

No.	REVISION DETAILS	BY	DATE	CLIENT:
F				FTS STD
E				DRAWN: R.BASILE
D				CHECKED:
C				APPROVED:
B	NOZ 1 WAS PHOENIX FLANGES, MONITOR WAS NPT	TAH	25-2-08	ORDER No:
A	ORIGINAL ISSUE			SCALE: N.T.S.

ITEM	QTY	DESCRIPTION	PART / SUB ASSM No.
10	1	STRIKER PLATE	SUB1047
9	2	LIFTING LUG - 5 TONNE C/W DOUBLER PAD	SUB1076
8	2	END SLIP IN 3462 ID x 8 PLATE	SUB1017
7	3	SHELL 3462 ID x 8 PLATE x 3000 LONG	SUB1041
6	1	50NB BSP MONITOR SOCKET C/W INTERNAL PIPE	SUB1083
5	1	FRP COLLAR	SUB1028
4	1	600NB MANWAY C/W 5 x 100NB SOCKETS	SUB1095
3	1	100NB FILL SOCKET C/W PIPE	SUB1058
2	1	100NB DIP SOCKET C/W PIPE	SUB1053
1	1	100NB BSP SOCKET	006395

TITLE: GENERAL ARRANGEMENT T90
GLASTEEL II U/G STORAGE VESSEL (8mm SHELL)

ESTIMATE NUMBER: N/A
DRAWING NUMBER: JW 090000-000

JOB No.: SHEET: 1 of 1 REVISION: B

VESEL CLASS N/A
SHEET SIZE A3

CLIENT: FTS STD
DATE: 11-07-01

PO BOX 102
CARRINGTON N.S.W. 2294
PHONE: (02) 4961-2745
FAX: (02) 4962-2812

THIS DRAWING & THE INFORMATION CONTAINED HEREIN IS THE PROPERTY OF FIBRETEK SYSTEMS AND IS STRICTLY CONFIDENTIAL & MUST NOT BE USED OR DISCLOSED WITHOUT WRITTEN CONSENT OF FIBRETEK SYSTEMS Pty LIMITED