

Technical Data Sheet

F 1005 REV B

ONGROUND STORAGE TANKS

Where space is not a limiting factor, FTS Onground tanks are traditionally used due to their initial cost, installation costs and maintenance benefits. FTS Onground tanks are supplied complete with steel cradles and access ladders. Optional products include manholes, alternative pipe locations, indirect fills and various coatings. Capacities range from 2,000 litres to 200,000 litres.

ONGROUND STEEL TANK FEATURES

A broad range of uses:

- Suitable for Petroleum, Petrochemical and Chemical applications

Strength and Durability you can depend on:

- Dished and flanged ends for improved strength
- Galvanised ladders and platform to Australian Standards
- Painting to customer specifications or code requirements
- Various shell thickness' available in 5, 6 and 8mm (depending upon capacity)

A standard of consistent quality:

- Manufactured to meet or exceed industry and statutory requirements:
 - AS 1940
 - AS 1692

COMPANY FEATURES

- Australian owned and operated
- Application and installation technical support
- Extensive manufacturing experience
- Full range of optional equipment and accessories to suit the complete project

DIMENSIONS AND CAPACITIES

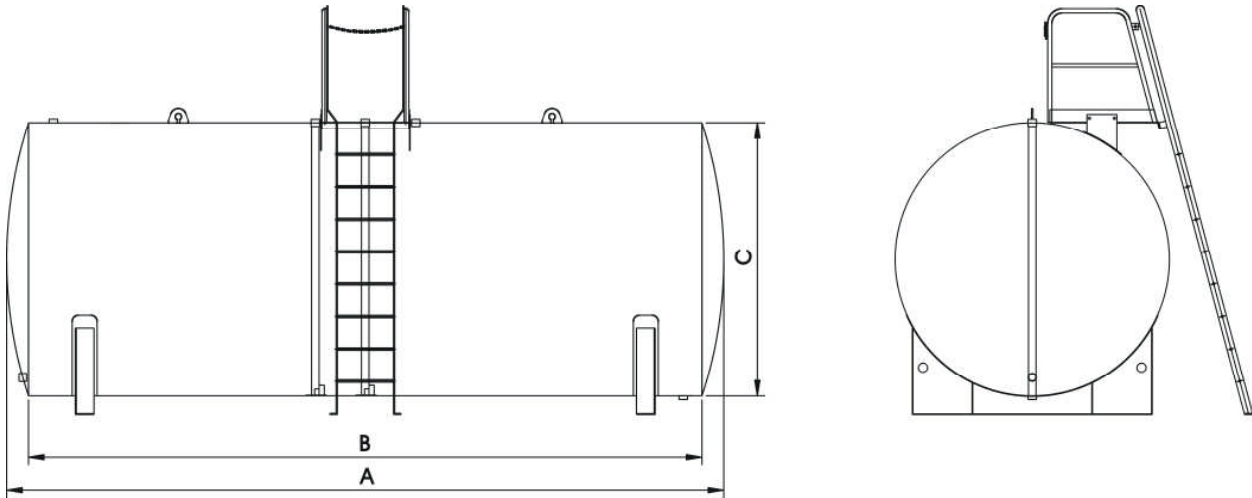

Type	Nominal Capacity Litres	Actual Capacity Litres	Dimensions – Millimetres					Weight kg
			A	B	C (I.D.)	Material		
						Body	End	
2	2,000	2,500	2,550	2,400	1,143	5	3	460
5	5,000	5,000	3,250	3,000	1,445	5	3	700
10	10,000	11,900	3,350	3,000	2,190	5	5	1,200
15	15,000	16,500	4,550	4,200	2,190	5	5	1,550
20	20,000	21,000	5,750	5,400	2,190	5	5	2,200
25	25,000	27,800	7,550	7,200	2,190	5	5	2,700
30	30,000	34,700	9,400	9,000	2,190	5	5	3,200
35	35,000	38,000	6,500	6,000	2,750	6	6	3,700
40	40,000	46,000	8,000	7,500	2,750	6	6	4,300
55	55,000	55,000	9,500	9,000	2,750	6	6	4,900
70	70,000	73,000	12,500	12,000	2,750	6	6	8,000
90	90,000	90,000	9,800	9,000	3,470	8	8	8,600
110	110,000	116,000	12,800	12,000	3,470	8	8	10,600

Weights, Capacities & Dimensions are nominal only

Custom manufactured tanks can be supplied upon request

Tanks are supplied as standard with:

- Lifting lugs (NOTE: Tank must only be lifted when empty)
- Fill, Dip, Vent, Discharge Socket, Drain Point and Dipstick
- Galvanised ladders and platforms fitted to Type 10 and above
- Cradles (150mm high)

Options and accessories available on request include:

- Access manways
- Alternative cradle heights to suit customer requirements
- Indirect fill assemblies an extra (80 NB or 100 NB) complete with fittings
- Additional connections and flanged nozzles – positioned to customers requirements