

## Fibreglass Single & Double Wall Tanks

# INSTALLATION MANUAL



## INTRODUCTION

It is important to follow the procedures and instructions in this manual in order to safely and properly install an FTS Underground Storage Tank. Failure to follow these instructions will void the tank warranty and may cause tank failure, serious personal injury, or property damage.

The FTS warranty applies to a tank installed according to these instructions. Since FTS does not control the parameters of any installation, our sole responsibility in any installation is that presented in our warranty.

Use the Tank Installation Checklist, accompanying this manual, as the installation proceeds. Retain a copy of the checklist, along with any deviation – authorisation letters, certification etc. in your files and return the original to FTS.

For Warranty to be effective, the completed Installation Checklist must be returned to FTS within 30 days (refer to Installation Checklist for more details). Consult your FTS representative or distributor for a supply of additional checklist forms. Comply with all applicable regulations and standards, such as:

- national, state and local construction, health, safety and environmental codes
- industry standard practices (eg. PEI/RP100, API RP1615 & EPA, CP-4, AS1692, AS1940)

For additional information, contact your state and local government authorities, including health, fire or building departments, and environmental agencies. All work must be performed according to standard industry practices and OH&S regulations.

An FTS requirement will never take precedence over a requirement imposed by any federal, state or local code or regulation. In all cases, any such requirement takes precedence over any provision of the FTS manual. FTS must authorise any variation to, or deviation from, these instructions. This authorisation must be made in writing, prior to tank installation.

**DEFINITIONS:** Throughout this text, these definitions will apply:

- **Socket fitting:** a fitting, either on a manway or on the tank shell, which opens into the primary containment vessel, where the tank's contents are normally stored;
- **Monitor fitting:** a fitting, located on the tank shell, which opens into the secondary containment vessel, which is the normal monitoring location on the tank.

For additional terminology, see Figure 0-1.

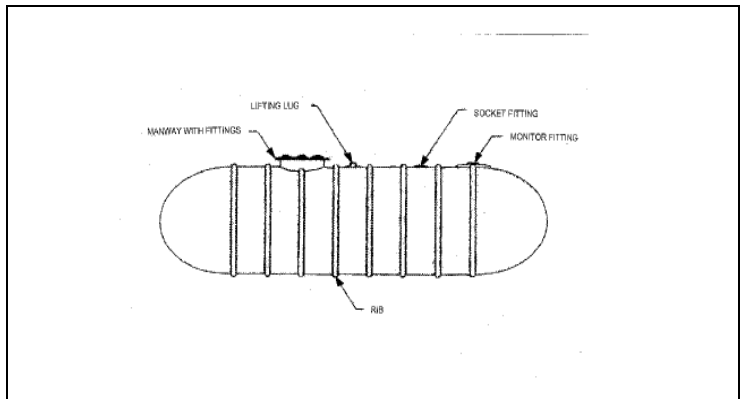

**FIGURE 0-1**

**If you have any questions or encounter any situations not covered in these installation instructions, please contact the FTS Technical Service Department on (02) 4961 2745.**

## SAFETY

Before beginning the tank installation, read through the entire installation manual. It is the installer's responsibility to comply with all safety precautions, codes and regulations. No instructions or procedures presented in this manual should be interpreted as to put at risk any person's health or safety or to harm any property or the environment. Keep the Installation Manual available at the installation to refer back to safety procedures as needed. The following definitions will serve as a guide when reading the Installation Manual:

**WARNING:** indicates hazards which, if not avoided, could cause death, serious personal injury or significant property damage.

**CAUTION:** indicates hazards which, if not avoided, may cause personal injury or property damage.

## 1. PREPARATION FOR INSTALLATION

**WARNING:** Working in excavations is dangerous and is regulated by safety codes. Careless activity or operation of equipment can cause death or serious personal injury.

Although the corrosion-resistant FTS tanks are rugged, care must be taken that they are not dropped or damaged during delivery, unloading and handling on the job site.

**WARNING:** The tanks are heavy and have a large surface area. The tanks will roll on sloped surfaces and can be blown about by the wind. Uncontrolled movement of the tanks can cause death, serious personal injury and property damage.

Before the tanks are unloaded or relocated on the job site:

- Be sure that all equipment used to lift the tanks is rated to handle the load.
- Prepare the unloading and/or storage site by removing all rocks and debris.
- Arrange for sandbags or tyres to be used as chocks.

Use the lifting lug(s) when hoisting the tank. **Do not wrap chain or cable around the tank.** Tanks larger than 45,000Litres have

multiple lifting lugs. Use all of the lugs to move the tank. (See Fig. 1-1).

**Use guy ropes to guide the tank when needed. Do not move the tank by rolling.**

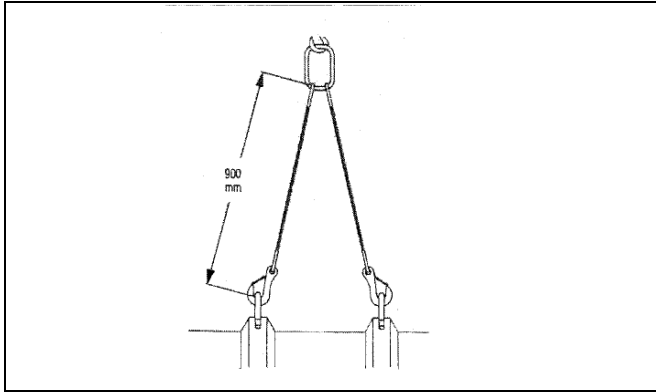

**FIGURE 1-1**

Whenever the tanks are stored at the site, chock them in place to prevent rolling. Tie them down if high winds are expected.

## 2. PREINSTALLATION TEST

### 2.1 GENERAL

FTS tanks are tested prior to shipment, but the tank must be checked at the site prior to installation – even if shipped with the optional vacuum in the interstitial space or wet interstitial space – in order to verify the absence of shipping and handling damage.

Visually inspect the tank exterior for damage. Any damage should be documented and FTS contacted immediately. If no damage is found, complete the appropriate section on the Installation Checklist. The Brine level should also be checked at this point. Record the brine level on the Installation Checklist. It is normal for the brine level to drop somewhat during transport, however if no brine is visible in the monitor, contact FTS.

The tester is responsible for verifying that all of the test equipment is in good working condition, and is properly configured and calibrated. Construct a test manifold with two air-supply gauges as shown in figure 2-1. Each air supply gauge must have a maximum full scale reading of 15 psig increments and a pressure relief device set at 6 psig.

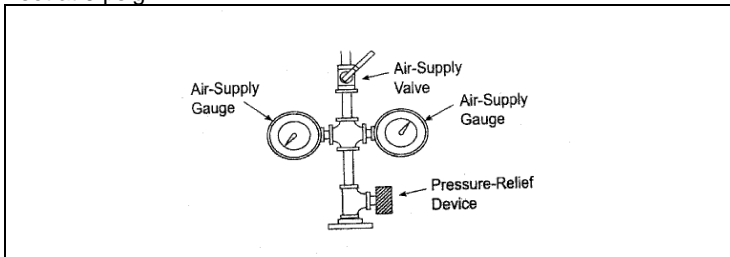

**FIGURE 2-1**

In air tests, temperature change could be a factor in changes in gauge readings.

**Note:** Multiple test manifolds are required to test multi compartment tanks.

It is the installer's responsibility to select a thread sealant that is compatible with the product being stored. Some sealants cannot be used with some products. Remove, clean and redope all factory furnished temporary plugs with appropriate thread sealant. Install

permanent plugs in all openings where piping will not be installed. Make sure all manway bolts are tightened, and fitting plugs are properly doped and sealed.

When checking the tank for leaks during an air/soap test, rotate the tank to check the bottom, unless it is a tank filled with monitoring fluid.

**Caution: Never rotate a tank filled with monitoring fluid. See Section 2.4 & Section 2.8 for instructions regarding these tanks**

Before rotating the tank during an air/soap test, place protective material on the area on which the tank will be rotated. Make sure the area is flat and is free of large or sharp objects, such as rocks, which may damage the tank.

Rotate the tank slowly and carefully to avoid developing too much momentum. Momentum can grow because fittings on top of the tank make it top heavy. Make sure the tank's fittings and manways never touch the ground. Do not rotate the tank more than 120 degrees from the initial starting point.

**WARNING: Always secure the tank before moving or lifting it. This is commonly done by connecting a crane to the lifting lugs. Failure to do so could result in death or serious injury.**

**WARNING: While moving or lifting the tank, do not position any part of your body underneath the tank. This could result in death or serious injury.**

**WARNING: Do not lift or hoist a tank under pressure. This could result in death or serious injury.**

Refer to the appropriate section below for instructions for the following situations:

- For testing a single wall tank, see Section 2.2.
- For testing a double wall tank with a dry interstitial space, see Section 2.3.
- For testing a double wall tank with a wet interstitial space, see Section 2.4.
- For testing a single wall multi compartment tank with a single wall bulkhead, see Section 2.5.
- For testing a single wall multi compartment tank with double wall bulkhead(s), see Section 2.6.
- For testing a double wall multi compartment tank with a dry interstitial space, see Section 2.7.
- For testing a double wall multi compartment tank with a wet interstitial space, see Section 2.8.

If damage is detected, do not attempt repairs. Contact the Production Manager at FTS on (02) 4961 2745.

After installation and before backfilling to grade, testing must be repeated to verify that no damage has occurred during installation.

**WARNING: When the tank is under pressure, the manways and/or fittings may dislodge, or the tank could rupture and result in death or serious injury. Before beginning the test, notify all people on the test site to remain in a safe location. ALWAYS ATTEND TO THE TANK DURING THE TEST. Stand clear of manways, fittings and tank ends during the test.**

**WARNING: The maximum test pressure is 5 psig. Position the pressure gauge so that the pressure readings can be clearly read at all times. Failure to follow this warning could result in death or serious injury (See Figure 2-2)**

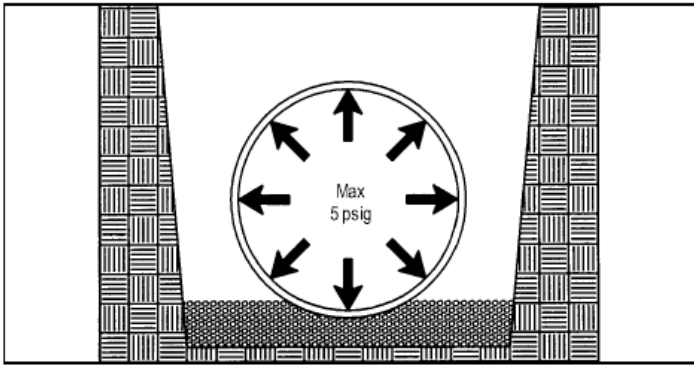

FIGURE 2-2

**WARNING:** The pressure relief device or regulated air source must be rated at a maximum of 6 psig to reduce the risk of over pressurising the tank. Failure to follow this warning could result in death or serious injury.

## 2.2 TESTING A SINGLE WALL TANK

Remove all temporary service fitting plugs.

Redope fittings and install plugs in all openings, except one service fitting (needed for the test manifold). Follow instructions in Point 2.1.

Install the test manifold in the open service fitting. Connect the pressure source to the test manifold (See Figure 2-3).

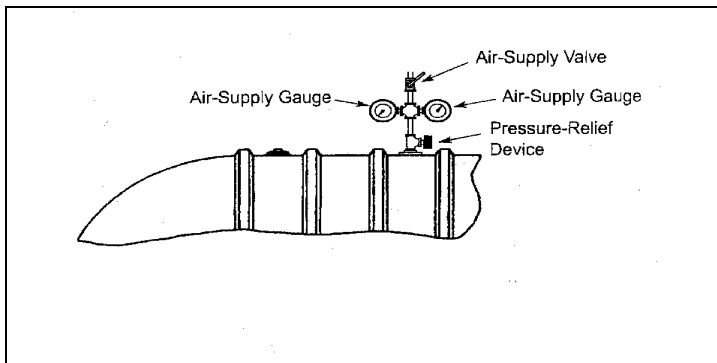

FIGURE 2-3

Pressurise the tank to 5 psig. Allow the pressure to stabilise by adding or removing air as necessary.

Close the air supply valve on the test manifold. Disconnect the air supply line.

Soap the entire exterior of the tank, checking for leaks. (Follow instructions in points 2.1 including warnings). Watch for active air bubbles, which indicate a leak. Pay special attention to fittings and manways.

Monitor the pressure for one hour.

When the test is complete, carefully release the air pressure from the tank by opening the air supply valve.

When airflow stops, remove the test manifold.

Replace the protective covers in the service fittings.

## 2.2 TESTING A DOUBLE WALL TANK WITH A DRY INTERSTITIAL SPACE

### GENERAL

Construct a quick-disconnect assembly. (See Figure 2-4).

### PRIMARY TANK (INTERNAL)

Remove all temporary service-fitting plugs.

Redope fittings and install plugs in all openings, except one service fitting (needed for the test manifold). Follow instructions in Point 2.1.

Install the test manifold in the open service fitting. Connect the pressure source to the test manifold. (See Figure 2-4).

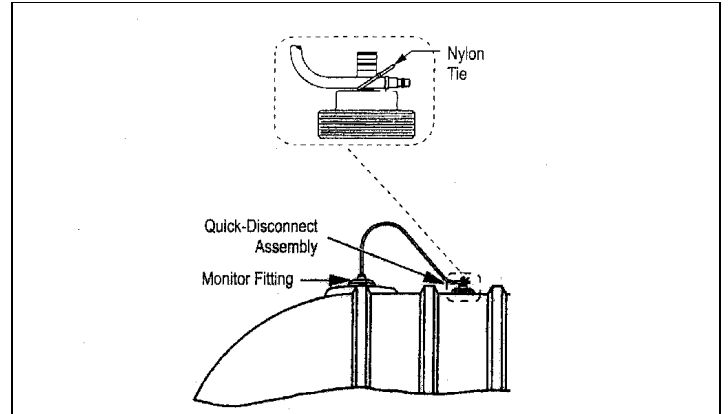

FIGURE 2-4

In order to test the primary tank alone, the quick-disconnect assembly must not be connected to the service fitting.

Pressurise the primary tank to 5 psig. Allow the pressure to stabilise by adding or removing air as necessary.

Close the air supply valve on the test manifold. Disconnect the air supply line.

Soap all service fittings and manways. Watch for active air bubbles, which indicate a leak.

Monitor the pressure for one hour.

### SECONDARY TANK (EXTERNAL)

Maintain the pressure in the primary tank.

**CAUTION:** Do not connect air supply directly to the interstitial space monitor fitting. Pressurising the secondary tank (interstitial space) by itself may damage the primary tank or cause tank failure.

Free the hose from the service fitting.

Insert the hose into the quick disconnect fittings. This will allow air to transfer from the primary tank to the secondary tank.

Reconnect the air supply line. Allow the pressure to stabilise at 5 psig by adding or removing air as necessary.

Close the air supply valve on the test manifold. Disconnect the air supply line.

Soap the entire exterior of the tank, checking for leaks. (Follow instructions in 9.1 including the warnings)

Watch for active air bubbles, which indicate a leak. Pay special attention to fittings and manways.

Monitor the pressure for one hour.

When the test is complete, carefully release the air pressure from the tank by opening the air supply valve.

When the airflow stops, remove the test manifold. Replace the protective covers in the service fittings.

## 2.4 TESTING A DOUBLE WALL TANK WITH A WET INTERSTITIAL SPACE

**CAUTION: Never pressurise a wet interstitial space. Doing so may damage the primary tank or cause tank failure.**

### PRIMARY TANK (INTERNAL)

Keep the tank vertical (the reservoir on top) at all times or the monitoring fluid may drain from the reservoir.

Remove all temporary service fitting plugs and the reservoir fitting plug. Check the monitoring fluid level in the reservoir. It should be about ½ full.

Visually check the interior of the tank for monitoring fluid. **There should not be any.**

Redope fittings and install plugs in all openings, except one service fitting (needed for the test manifold) and the reservoir fitting.

Following instructions in Point 2.1. **Do not open the monitor fitting (if present) or monitoring fluid could be lost.**

Install the test manifold in the open service fitting. Connect the pressure source to the test manifold (See Figure 2-4)

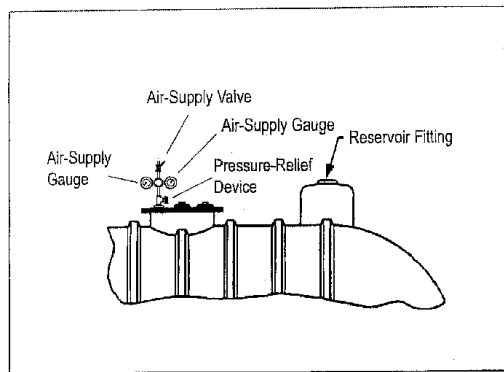

FIGURE 2-5

Pressurise the primary tank to 5 psig. Allow the pressure to stabilise by adding or removing air as necessary.

Close the air supply valve on the test manifold. Disconnect the air supply line.

Soap all service fittings and manways. Watch for active air bubbles, which indicate a leak. Look through the laminate for any active air bubbles rising to the top. Their presence would indicate an internal leak.

Also, check the reservoir for bubbles in the monitoring fluid. **(The monitoring fluid level will rise during the air test).**

Monitor the pressure for one hour.

When the test is complete, carefully release the air pressure from the tank by opening the air supply valve.

When the airflow stops, remove the test manifold.

Check the level of the monitoring fluid in the reservoir. It should be at approximately the same level as the pre-test level.

## SECONDARY TANK (EXTERNAL)

**CAUTION: Never pressurise a wet interstitial space. Doing so may damage the primary tank or cause tank failure.**

Check the exterior of the tank for monitoring fluid. (The monitoring fluid is dyed blue to distinguish between moisture and monitoring fluid) If monitoring fluid is found, wipe the tank dry and verify that the monitoring fluid does not reappear. Lift the tank to check the bottom. **Do not roll the tank.**

**WARNING: Do not lift the tank when the tank is under pressure. This could result in death or serious injury.**

Visually check the interior of the tank for monitoring fluid. **There should not be any.**

Replace the protective covers in the service fitting and the reservoir fitting.

## 2.5 TESTING A SINGLE WALL MULTI COMPARTMENT TANK WITH A SINGLE WALL BULKHEAD

### GENERAL

Remove all temporary service fitting plugs.

Redope fittings and install plugs in all openings, except one service fitting in each compartment (needed for the test manifolds). Follow instructions in point 2.2 (See Figure 2-6 and Figure 2-7)

Before doing the air test of the base tank (described in Section 2.5 Air Test of Base Tank) and the air test of the end tank(s) (described in Section 2.6 Air Test End Tanks), install the test manifolds on the base and end tanks(s).

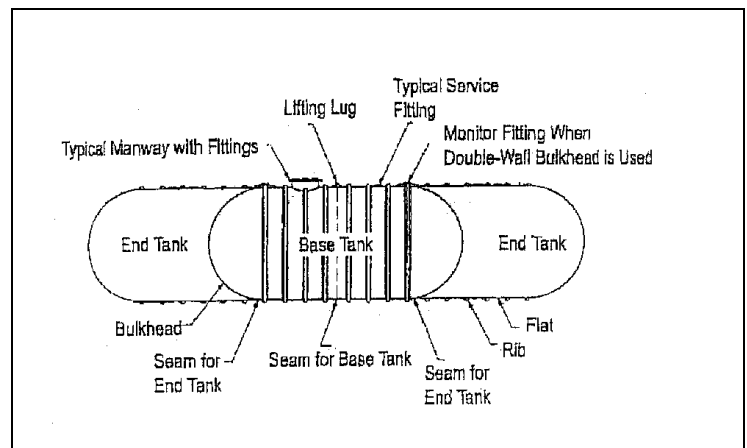

FIGURE 2-6

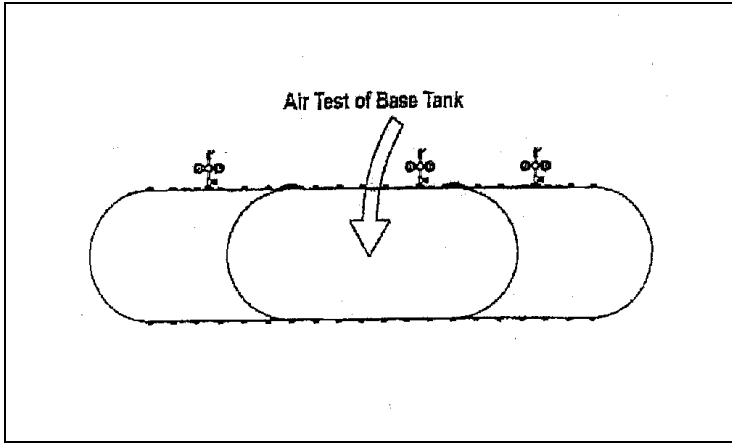

FIGURE 2-7

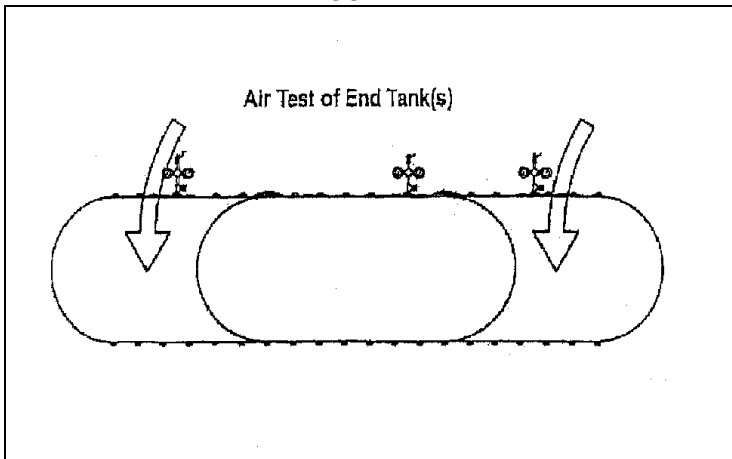

FIGURE 2-8

**AIR TEST OF BASE TANK**

Connect the pressure source of the test manifold on the base tank. (see Figure 2-3 and Figure 2-7).

Pressurise the base tank to 5 psig. Allow the pressure to stabilise by adding or removing air as necessary.

Close the air supply valve on the test manifold in each compartment. Disconnect the air supply line.

Monitor the pressure for one hour. **Do not release air pressure.**

**AIR TEST OF END TANK(S)**

Connect the pressure source to the test manifold on the end tank(s). (See Figure 2-3 and Figure 2-8)

Pressurise the end tank(s) to 5 psig. Allow the pressure to stabilise by adding or removing air as necessary.

Close the air supply valve on the test manifold. Disconnect the air supply line.

**EXTERNAL SOAP TEST**

Soap the entire exterior of the tank, checking for leaks. (Follow instructions in point 2.1 including warnings) Watch for active air bubbles, which indicate a leak. Pay special attention to fittings and manways. **Monitor the pressure for one hour.**

After the test is completed, release all tank air pressure and remove gauges. Replace the protective covers in the service fittings.

**2.6 TESTING A SINGLE WALL MULTI COMPARTMENT TANK WITH DOUBLE WALL BULKHEAD(S)**

**CAUTION: Do not connect air supply directly to the interstitial space monitor fitting. Pressurising the secondary tank (interstitial space) by itself may damage the primary tank or cause tank failure.**

**GENERAL**

Remove all temporary service fitting plugs.

Redope fittings and install plugs in all opening , except one service fitting in each compartment (needed for the test manifolds). Follow instructions in Point 2.5 (see Figure 2-6 and Figure 2-7).

Before doing the air test of the base tank (described in Section 2.5) and the air test of the end tank(s) (described in Section 2.5), install the test manifolds on the base and end tank(s).

**AIR TEST OF BASE TANK**

Connect the pressure source to the test manifold on the base tank. (See Figure 2-3 and Figure 2-7).

Pressurise the base tank to 5 psig. Allow the pressure to stabilise by adding or removing air as necessary.

Close the air supply valve on the test manifold on the base tank. Disconnect the air supply line.

Soap the fittings on top of the base tank to make sure fittings are not leaking. Watch for active air bubbles, which indicate a leak. Monitor the pressure for one hour. **Do no release air pressure.**

**AIR TEST OF END TANK(S)**

Connect the pressure source to the test manifold(s) on the end tank(s). (See Figure 2-3 and Figure 2-8).

Pressurise the end tank(s) to 5 psig. Allow the pressure to stabilise by adding or removing air as necessary. Close the air supply valve on the test manifold. Disconnect the air supply line.

**TEST OF DOUBLE WALL BULKHEAD(S)**

After the primary and secondary tanks have been pressurised, install a 4 inch NPT plug with a 0-15 psig gauge into all monitor fittings leading into the double wall bulkhead(s). (See figure 2-9).

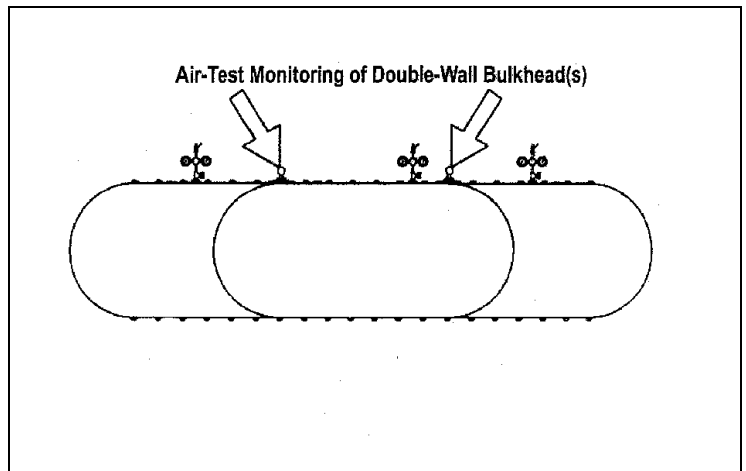

FIGURE 2-9

## EXTERNAL SOAP TEST

Soap the entire exterior of the tank, checking for leaks. (Follow instructions in Points 2.1 including warnings)

Watch for active air bubbles, which indicate a leak. Pay special attention to fittings and manways.

Monitor the pressure for one hour.

Monitor all gauges for either a loss in pressure from the tanks or an increase in pressure in the bulkhead interstitial space.

After the test is completed, release all tank air pressure and remove gauges.

Replace the protective covers in the service fittings.

## 2.7 TESTING A DOUBLE WALL MULTI COMPARTMENT TANK WITH A DRY INTERSTITIAL SPACE

**CAUTION: Do not connect air supply directly to the interstitial space monitor fitting. Pressurising the secondary tank (interstitial space) by itself may damage the primary tank or cause tank failure.**

### GENERAL

Remove all temporary service fitting plugs.

Redope fittings and install plugs in all openings, except one service fitting in each compartment (needed for the test manifolds). Follow instructions in point 2.1 (See Figure 2-10 and Figure 2-11). Construct a quick disconnect assembly. (See Figure 2-4).

If the tank is not configured, as shown in Figure 2-4 prior to pre-installation testing, call the Production Manager at FTS.

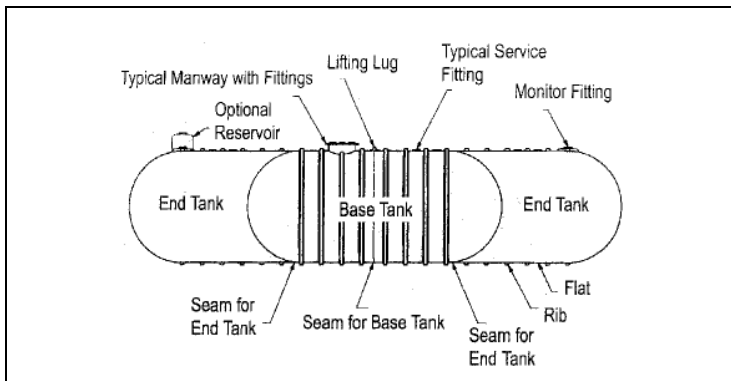

FIGURE 2-10

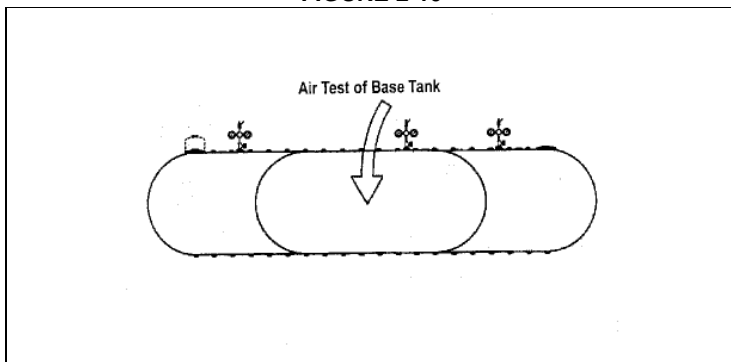

FIGURE 2-11

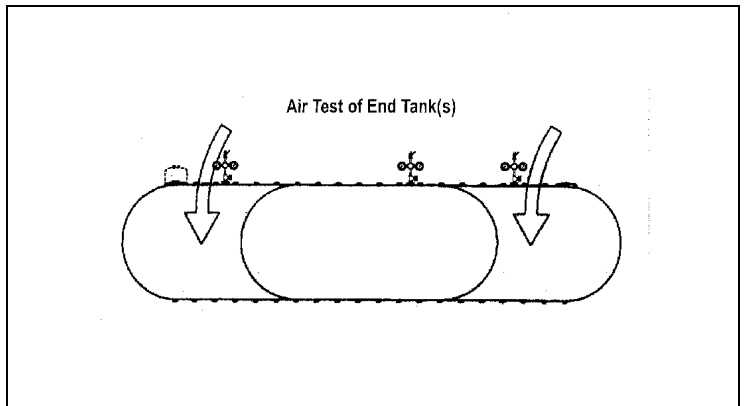

FIGURE 2-12

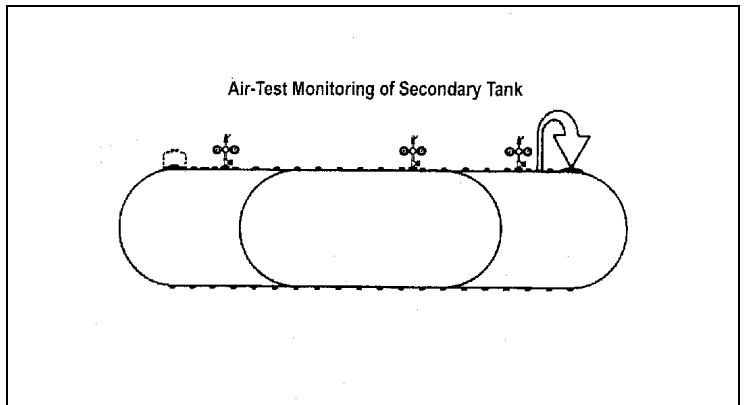

FIGURE 2-13

### AIR TEST OF BASE TANK

Connect the pressure source to the test manifold on the base tank. (See Figure 2-3 and Figure 2-11).

Pressurise the base tank to 5 psig. Allow the pressure to stabilise by adding or removing air as necessary.

Close the air supply valve on the test manifold on the base tank. Disconnect the air supply line. Soap all service fittings and manways on the base tank. Watch for active air bubbles, which indicate a leak.

Monitor the pressure for one hour. **Do not release air pressure.**

### AIR TEST OF END TANK(S)

Connect the pressure source to the test manifold on the end tank(s). (See Figure 2-3 and Figure 2-12).

Pressurise the end tank(s) to 5 psig. Allow the pressure to stabilise by adding or removing air as necessary.

Close the air supply valve on the test manifold on each end tank. Disconnect the air supply line. Soap all service fittings and manways on the end tank(s). Watch for active air bubbles, which indicate a leak.

**Monitor the pressure for one hour.**

### AIR TEST OF SECONDARY TANK

Attach the quick disconnect hose assembly from the monitor fitting to the primary tank service fitting (with a female quick disconnect fitting in place). This will allow air to transfer to the interstitial space. (See Figure 2-4 and Figure 2-13).

Add air as required and stabilise the air pressure in the total tank system to 5 psig.

### EXTERNAL SOAP TEST

Soap the entire exterior of the tank, checking for leaks. (Follow instructions in points 2.2 including warnings) Watch for active air bubbles, which indicate a leak. Pay special attention to fittings and manways.

Monitor the pressure for one hour.

When the test is completed, carefully release the air pressure from the tank by opening the air supply valve. When the airflow stops, remove the test manifold. Replace the protective covers in the service fittings.

## 2.8 TESTING A DOUBLE WALL MULTI COMPARTMENT TANK WITH A WET INTERSTITIAL SPACE

**CAUTION: Never pressurise a wet interstitial space. Doing so may damage the primary tank or cause tank failure.**

### GENERAL

See Figure 2-10 for reference.

### BASE TANK'S PRIMARY (INTERNAL) TANK

Keep the tank vertical (the reservoir on top) at all times or the monitoring fluid may drain from the reservoir.

Remove all temporary service fitting plugs and the reservoir fitting plug.

Check the monitoring fluid level in the reservoir. It should be about ½ full.

Visually check the interior of each compartment for monitoring fluid. **There should not be any.**

Redope fittings and install plugs in all openings, except one service fitting in each compartment (needed for the test manifolds) and the reservoir fitting. *Following instructions in point 2.1* (See Figure 2-6 and Figure 2-7).

Before doing the air test of the base tank (Described in Section 2.8) and the air test of the end tank(s) (Described in Section 2.8), install a test manifold in the open service fitting on both the base and end tank(s)

### AIR TEST OF BASE TANK'S PRIMARY TANK

Connect the pressure source to the test manifold on the base tank (See Figure 2-3 and Figure 2-11).

Pressurise the primary tank of the base tank to 5 psig. Allow the pressure to stabilise by adding or removing air as necessary.

Close the air supply valve on the test manifold on the base tank. Disconnect the air supply line. Soap all service fittings and manways. Watch for active air bubbles, which indicate a leak. Look through the laminate for any active air bubbles rising to the top. Their presence would indicate an internal leak. Also, check the reservoir for bubbles in the monitoring fluid. **(The monitoring fluid level will rise during the air test).**

Monitor the pressure for one hour. **Do not release air pressure.**

### AIR TEST OF END TANK(S)' PRIMARY TANK(S)

Connect the pressure source to the test manifolds on the end tanks(s). (See Figure 2-3 and Figure 2-12).

Pressurise the primary tank of the end tank(s) to 5 psig. Allow the pressure to stabilise by adding or removing air as necessary. **(The monitoring fluid level will rise during the air test)**

Close the air supply valve on the test manifolds on the end tanks. Disconnect the air supply line.

Soap all service fittings and manways. Watch for active air bubbles, which indicate a leak. Check the reservoir for bubbles in the monitoring fluid. **(The level of the monitoring fluid will naturally rise due to the pressure in the primary tank).**

Monitor the pressure for one hour.

When the test is complete, carefully release the air pressure from all compartments by opening the air supply valve. When the air flow stops, remove the test manifolds.

Check the monitoring fluid level in the reservoir. It should be at approximately the same level as the pre-test level.

### SECONDARY TANK (EXTERNAL)

Check the exterior of the tank for monitoring fluid. (The monitoring fluid is dyed blue to distinguish between moisture and monitoring fluid). If monitoring fluid is found, wipe the tank dry and verify that the monitoring fluid does not reappear. Lift the tank to check the bottom. Do not roll the tank.

Visually check the interior of the tank for monitoring fluid. **There should not be any.**

Replace the protective covers in the service fittings and the reservoir fitting.

## 3. BACKFILL AND BEDDING

FTS recommends tanks be installed using either pea gravel or crushed stone which meets the following specifications.

**GENERAL:** The material is washed and free flowing and conforms to the specification of AS2758 and AS1141. No more than 5% (by weight) of the material may pass through a 2.36mm sieve.

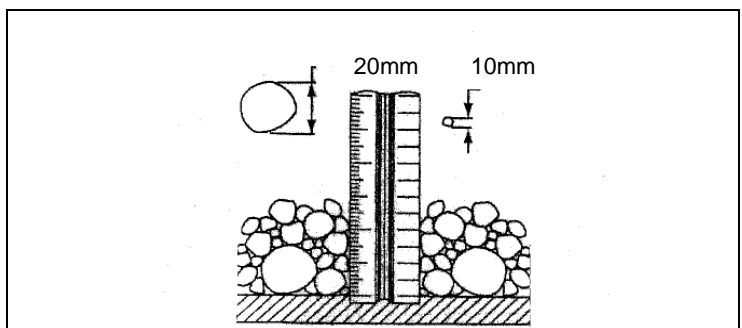

Pea Gravel

**PEA GRAVEL:** Mix of rounded particles – sizes between 10mm and 20mm.

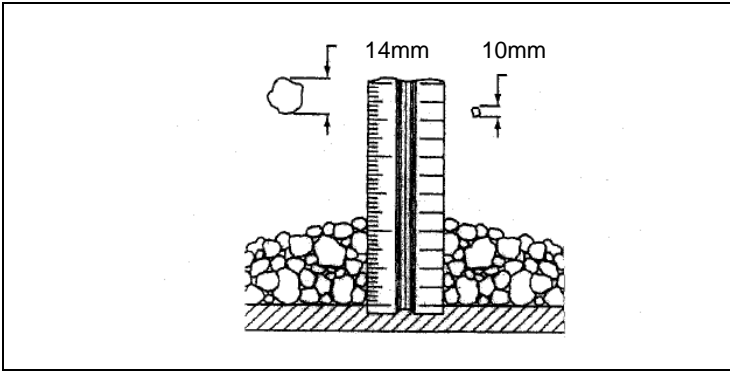

**Crushed Stone**

**CRUSHED STONE:** Mix of angular particles – sizes between 10mm and 14mm.

It is recommended that the supplier certify that the material conforms to AS2758 and any other applicable specifications. (For additional information, refer to the FTS pamphlet *Fibreglass Tank Backfill Guidelines*).

**NOTE:** If material which meets these specifications is not available, contact the FTS Technical Service Department for information on approved alternate materials and installation instructions.

Using other than approved bedding and backfill materials without FTS prior written approval will void the tank warranty and may result in tank failure.

#### 4. EXCAVATION PARAMETERS

The installing contractor must take all precautions necessary to protect employees working in or near a tank excavation. These precautions should include, but are not limited to:

- Location and protection of any utility installations near the excavation before opening the excavation;
- Means of securing the walls of the excavation;
- Means of preventing exposure of employees to hazardous fumes from the excavation;
- Protection of employees from hazards associated with water accumulation in the excavation;
- Barricades, etc. to prevent unauthorised vehicle or pedestrian traffic;
- Inspection of the excavation and surrounding area at least daily.

The minimum depth of the excavation is normally determined by the presence or absence of groundwater and the presence or absence of traffic at the site. These dimensions are critical to the successful installation of a tank.

Tanks subjected to traffic loads must have a cover depth of at least 450mm of backfill plus 230mm of asphalt. An acceptable alternative is a minimum of 450mm of backfill plus 150mm of reinforced concrete.

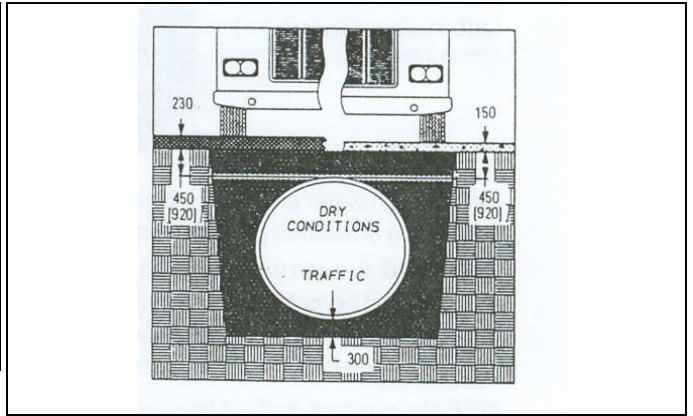

Tanks subjected to traffic loads and high water must have a minimum of 760mm of backfill and either 230mm of asphalt or 150mm of reinforced concrete and must be anchored.

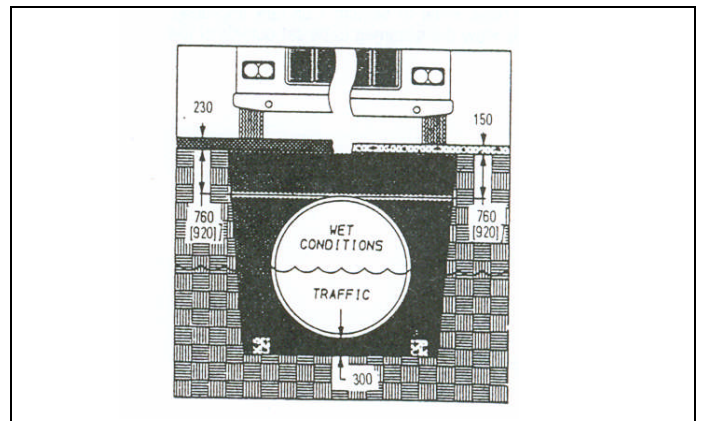

Tanks not subjected to traffic loads must have a minimum cover depth of 600mm of backfill, or 300mm backfill plus 100mm of reinforced concrete or 150mm of asphalt.

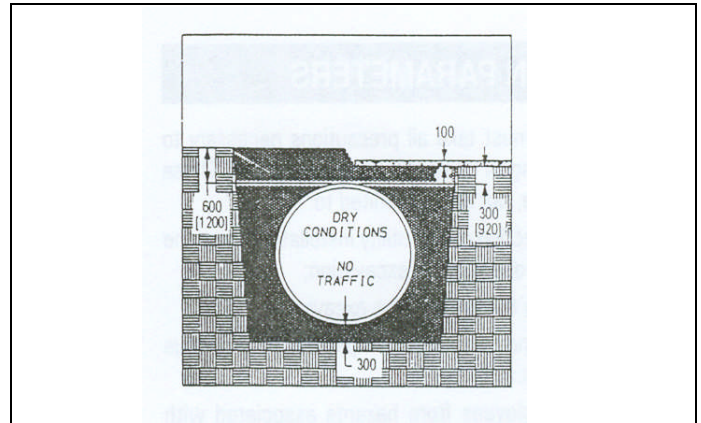

Tanks in high water areas not subjected to traffic loads must have a minimum of 1 Metre of backfill covering and must be anchored.

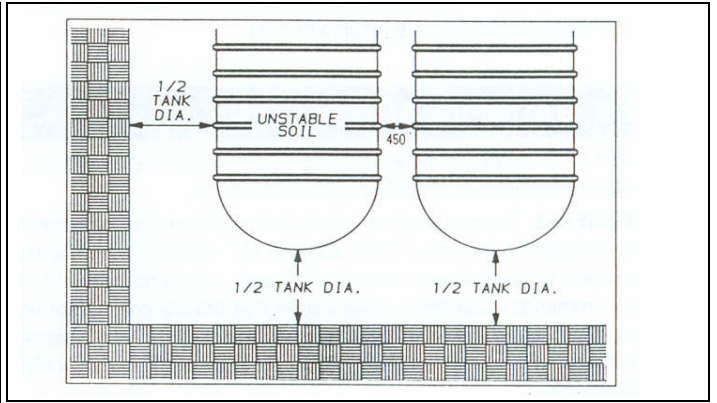
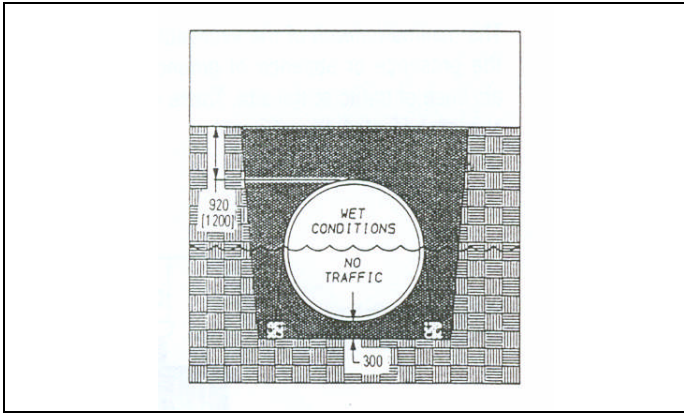

**WARNING:** In a non traffic installation, ensure that the areas above the tanks will never be subject to traffic load, which could cause tank damage and result in death or serious injury.

**NOTE:** These depths of cover are MINIMUMS in all cases.

**NOTE:** Asphalt and concrete pads must extend a minimum of 300mm beyond tank in all directions.

**NOTE:** Maximum burial depth is 2.1m of cover over top of tank.

**NOTE:** Manway riser (if present) must not transmit load from the slab to the tank. There must be a minimum 150mm space between the bottom of the slab and the top of the riser.

## 5. TANK SPACING

**NOTE:** These are minimum spacings and must be increased as needed to accommodate deadmen or anchor slabs. Refer to Section 6 on tank anchoring. Always allow sufficient clearance to allow the deadmen to be set outside of the tank shadow. The relevant Australian Standard (AS1940) specifies the minimum tank separation distances.

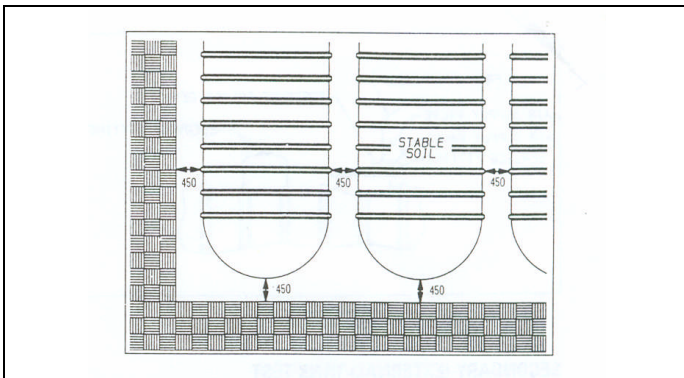

### STABLE SOIL CONDITIONS

Where shoring is not required to maintain a vertical wall from top to bottom of the excavation, the minimum spacing between the sidewall or endcap of the tank and side of excavation must be 450mm. If more than one tank is to be installed in the same hole, there must be at least 450mm between the tanks.

### UNSTABLE SOIL CONDITIONS

If the soil has less than 36 kpa/m<sup>2</sup> cohesion as calculated from an unconfined compression test; or soils having an ultimate bearing capacity of less than 168 kpa/m<sup>2</sup> or where soil will not maintain a vertical wall, the excavation must allow a minimum space equal to 1/2 the diameter of the tank between the side and endcap of the tank and the excavation wall. The spacing between adjacent tanks, 450mm remains the same.

### FILTER FABRIC

The tank owner or his technical representative is responsible for determining whether filter fabric or an alternate filtering technique is appropriate for a specific installation.

Filter fabric allows the passage of water but prevents the migration and mixing of native soil and backfill material. It preserves the integrity of the backfill envelope which supports the tank. Polyethylene film is not considered an effective material to prevent migration of pea gravel and native soil; it may tear or degrade while in service.

FTS recommends that filter fabric be used when the tank may be installed in:

- Areas with frequently changing ground water conditions or areas subject to tidal fluctuations,
- Unstable soils such as bog, swamp, landfill or mud,
- Wet conditions with silty soil.

For further information concerning fabric specifications and installation procedures, consult the filter fabric supplier's installation guides or instructions.

To install filter fabric, typically filter fabric manufacturers recommend that the installer line the excavation sides and bottom with the fabric. Overlap adjoining panels by at least twelve inches. Place backfill material on the panels around the edge of the hole to anchor them in place.

In wet-hole conditions, use backfill material to sink and hold the fabric in place on the bottom of the hole.

## 6. ANCHORING TANK HOLD DOWN STRAPS

**CAUTION:** FTS recommends that every site be thoroughly evaluated for the potential to trap water or otherwise subject the tank to a rise in the local water table. FTS recommends that all tanks be anchored in installations in which water may enter the hole. Failure to anchor may damage the tank or surrounding property.

**WARNING: Only use the anchor points when lifting and positioning the deadmen. A spreader bar may be required to lift longer sections of deadmen. Use guy ropes to guide the deadmen when lifting. Failure to do so could result in death or serious injury.**

**DEADMAN ANCHOR**

A deadmen is a reinforced concrete beam with a total length 300mm greater than the overall length of the tank. A deadmen may be fabricated in multiple sections as long as the total length is not decreased and each section contains at least two anchor points. The width and thickness depend on the tank diameter. Refer to Table 6-1 for specific dimensions.

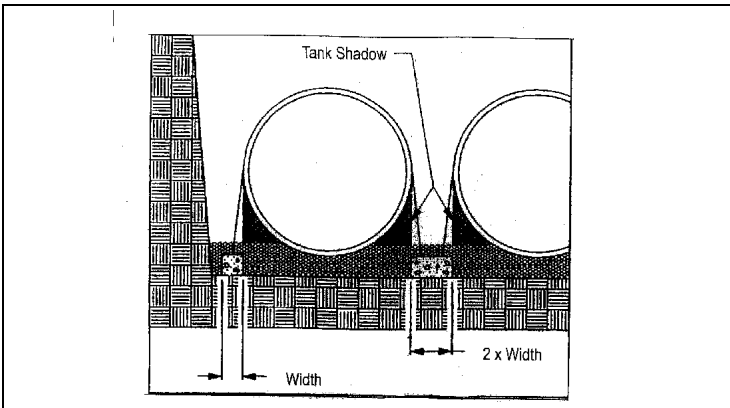
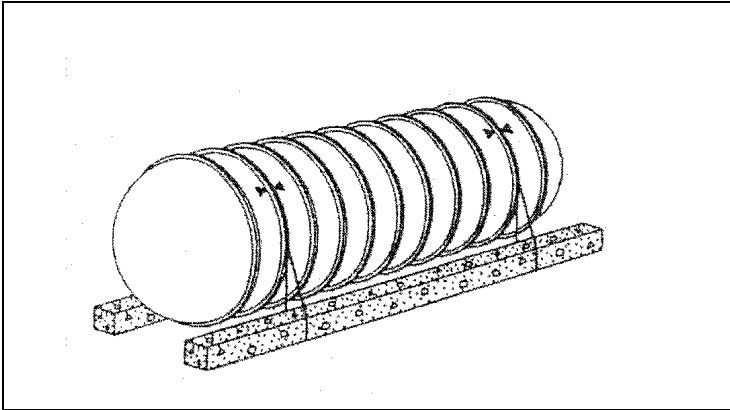

**FIGURE 6-1  
TABLE 6-1**

TANK DIA. (M)	DEADMEN DIMENSIONS (W X D) (mm)	SLAB WIDTH (M)
1.5	150 x 150	1.8
2.4	300 x 300	3.0
3.3	450 x 300	3.6

Lay the deadmen in the excavation parallel to the tank and outside of the tank "shadow" (see Figure 6-1). In multiple tank installations, each tank will require two deadmen.

The minimum spacing between tanks must be equal to twice the width of a single deadman. One deadman may be used between two tanks if it is double in width. Provide a separate anchor point for each hold down strap.

Deadmen are to be butted together where multiple sections are used. Place A to A and AA to AA (Marked on Deadmen).

**ANCHOR SLAB**

An anchor slab is a reinforced concrete base. The total length of the slab is 300mm greater than the overall length of the tank. The minimum slab thickness is 200mm. The width of the slab depends on the tank diameter. Refer to Table 6-1 for specific dimensions. Refer to Table 6-2 and Figure 6-2 for anchor point dimensions. Provide a separate anchor point for each holddown strap. When using a concrete base slab, allow sufficient depth in the excavation for 300mm of bedding material below the tank.

**TABLE 6-2**

TANK DIA.	DIM "A"	DIM "B"	DIM "C"	DIM "E" MIN / MAX	DIM "D"
1470	430	130	650	810 960	2850
2438	1143	838	381	1370 1120	4597
3275	990	690	947	1862 2012	7010

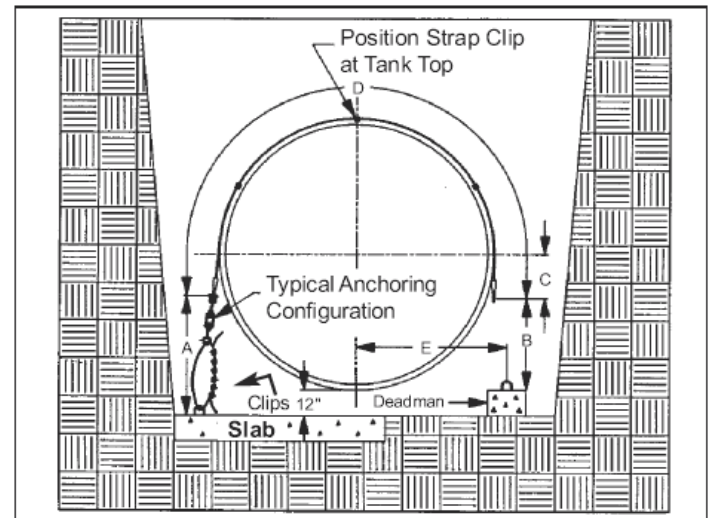

**FIGURE 6-2**

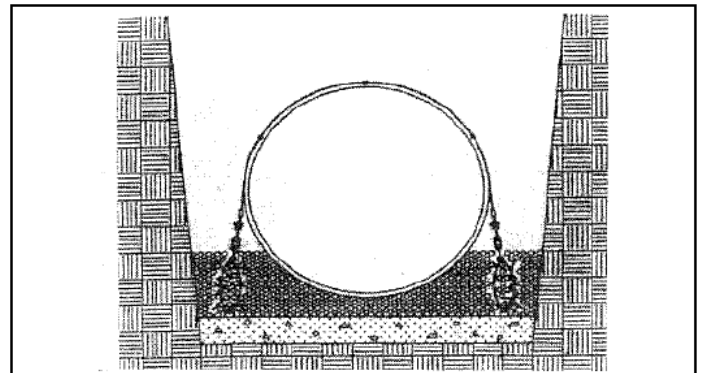

**NOTE:** When fastening wire cable, use a minimum of three clamps on each joint. Use shackle type or chair type clamps as appropriate

#### HOLDDOWN STRAPS:

FTS Hold Down Straps should be used when a tank is to be anchored. The location of the straps are marked on the tank by the ►◄ symbols. An installation guide is provided as a separate booklet.

**CAUTION:** Place the straps only in the locations designated by the arrow symbols ►◄.

A measurement must be taken of the tank diameter before the straps are tightened (Measurement A on the Installation Checklist - Refer to Section 14 for methodology)

To evenly distribute buoyancy loads tighten all hold down straps uniformly but cause no deflection of the tank.

An intermediate (intermediate 1) measurement should be taken of the tank diameter after the straps have been tightened. This should be compared with measurement A to ensure tank is inside the deflection allowance (see Deflection Allowance table on Installation Checklist and Section 14 for methodology)

**NOTE:** All exposed metal on the hold down straps, turnbuckles and/or threaded rod must be coated or galvanised to prevent corrosion.

## 7. DRY HOLE INSTALLATION

**CAUTION:** FTS recommends that every site be thoroughly evaluated for the potential to trap water or otherwise subject the tank to a rise in the local water table. FTS recommends that all tanks be anchored in installations in which water may enter the hole. Failure to anchor the tank in a wet hole may damage the tank or surrounding property.

Following installation of anchors, prepare a smooth level bed, 300mm thick (to top of anchors), of approved backfill material. Place the tank or tanks onto the bed. Do not set FTS tanks directly onto a concrete slab or on timbers, cradles or directly onto the hole bottom.

Levelling: As the tank is being placed, set the tank pitch as shown on the site plans. FTS does not require that a tank be pitched. All pitch is determined by the tank owner's specification.

If a double wall tank is pitched, the monitor should be at the low end. Use the tops of the ribs to establish longitudinal level. Establish lateral level by placing the level across the top of a fitting, a manway or a collar. When the tank is placed, take the first internal diameter reading (Deflection reading "A" on the checklist). See Section 14 for instructions on taking deflection readings. Before backfilling, do a visual inspection on the tank, if no damage is found, note this on the Installation Checklist and continue to follow these instructions. If damage is found, contact FTS.

#### BACKFILLING

Use only approved backfill material (See Section 3). Do not mix approved material with sand or native soil. Do not use native soil as backfill material. All excavated native soil must be replaced with approved material. Place one 300mm lift of material evenly around the tank. From the hole side or the top of an adjacent tank, work the material by hand completely beneath the tank body and domes to provide full support. Use a probe long enough to reach beneath

the tank and push the backfill in place. Repeat this setup with a second 300mm lift. After the second lift of material has been placed and probed, the backfill can be brought to the top of the tank without further hand work.

**CAUTION:** Do not strike the tank with the tamping bar. The tank may be damaged and require repair.

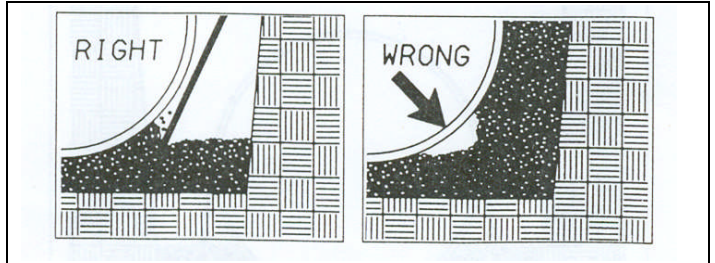

When the tank is backfilled to the tank top:

- Take a second intermediate diameter reading as an in process check, compare to the original measurement A to ensure the tank does not lie outside the maximum deflection range outlined on the Installation Checklist. DO NOT proceed to grade if the deflection is excessive.
- Complete the air test outlined in Section 9 – Post Installation Testing.

#### SUMMARY

1. Prepare the tank bed
2. Set and level the tanks
3. Measure the tank diameter
4. Install hold down hardware (refer to Section 6)
5. Conduct a visual inspection of the tank
6. Place and probe the first two lifts of backfill material
7. Add backfill to the top of the tank
8. Measure the tank diameter and complete the test

After the air test and measurement of tank deflection are successfully completed, it is recommended that the tank be ballasted until piping installation and final backfilling to grade is completed. When filling the tank make sure that the tank is adequately vented. The vent must be large enough to allow the displaced air to escape.

**NOTE:** Do not ballast the tank until the backfill is even with the top of the tank.

**WARNING:** If product is used as ballast, exercise special care in handling. Safeguard against sparks, fire or product spills. Improper handling of product can cause a fire or explosion, and death, severe personal injury or property damage.

## 8. WET HOLE INSTALLATION

**CAUTION:** Never allow an empty tank to remain in a wet hole, or a dry hole that may become wet unless anchoring and backfilling have been completed. Failure to anchor and backfill may damage the tank or surrounding property.

Pump the water from the hole to maintain minimum water level. Position anchors, refer to Section 6. Add a minimum of 300mm of well-placed backfill material to the hole, and level the bed to assure uniform bottom support for the tank. Position the tank in the hole. Partially ballast tank until it settles firmly on the prepared bed. Ballast level in a tank must never exceed water level in hole during installation. Use only enough ballast to sink the tank until backfill material is even with the top of the tank.

**WARNING:** If product is used as ballast, exercise special care in handling. Safeguard against sparks, fire or product spills. Improper handling of product can cause a fire or explosion, and death, severe personal injury or property damage.

After levelling tanks, the anchoring procedures in Section 6 must be followed. Backfill must be added evenly after anchoring, and remaining dry hole backfilling procedures should be followed.

**NOTE:** Cover depth must meet minimum depth specified in these installation instructions.

**NOTE:** It is recommended that the tank be completely ballasted once backfill is even with the top of the tank.

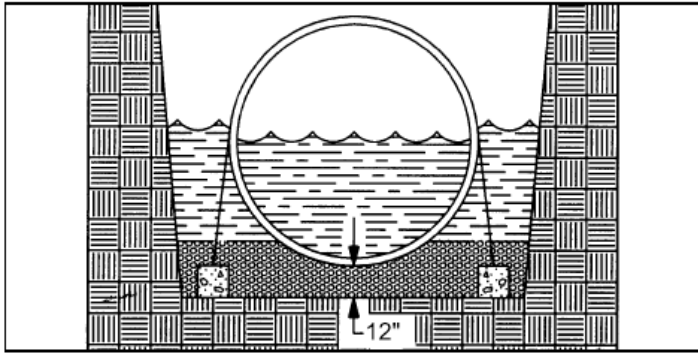

## 9. POST INSTALLATION TESTING

**WARNING:** Do not use air pressure to test tanks that contain flammable or combustible liquids or vapours. The fuel/air mixture may explode and cause death, severe personal injury or property damage. Tanks that will be ballasted with a flammable product should be air tested before ballasting.

### SECOND INTERMEDIATE DEFLECTION MEASUREMENT

After backfill is brought to the top of the tank, make an intermediate measurement of vertical deflection according to the instructions in the Section 14 (see Installation Checklist for deflection allowance)

### TEST

After the tank has been measured and vertical deflection is determined to be within the limits specified by FTS, the tank must be tested to ensure that no damage occurred during installation.

Following the procedures in Section 2 soaping all exposed areas of the tank fittings and monitor the pressure for one hour.

Carefully relieve the pressure in the tank and remove the test assembly from the tank.

## 10. BALLASTING

**WARNING:** If product is used as ballast, exercise special care in handling. Safeguard against sparks, fire or product spills. Improper handling of product can cause a fire or explosion and may result in death, severe personal injury or property damage.

The tank may be ballasted after the backfill is even with the top of the tank and post-installation testing has been successfully completed.

Only under wet-hole conditions as described in Section 8, should ballast be added before the backfill is even with the top of the tank. When filling the tank, make sure the tank is properly vented.

The vent must be large enough to allow the displaced air to escape.

## 11. PIPING AND VENTING

**CAUTION:** All internal piping must be at least 100mm from the tank bottom.

Refer to Table 11-1 to determine the correct dimensions to size internal pumps and piping.

When the tank's interstitial space is filled with a liquid, the space must be vented. It is sufficient to drill a ¼" diameter hole in the side or cap of the monitor system riser pipe.

When the groundwater level will be high enough to enter a drilled vent hole, install a separate vent line from the riser pipe to above grade level.

When the interstitial space is dry, it is not necessary to vent the space to atmosphere.

It is the installer's responsibility to select a thread sealant that is compatible with the product being stored.

Some sealants cannot be used with some products. If necessary, remove, clean and re-dope all plugs.

**WARNING:** All underground tanks/compartments shall be adequately vented to prevent the development of vacuum or pressure when filling or emptying the tank. Failure to properly vent a tank or compartment could cause tank failure and result in death or serious injury.

**WARNING:** FTS does not recommend pump- or pressure-filling of the tanks because an overfill or over pressurization could occur. Over filling the tank while under pressure could cause tank failure even if the tank vent is unrestricted. Tank failure could result in death or serious injury.

**WARNING:** If owner/operator allows pump- or pressure-filling of the tank, owner/operator must ensure that the tank is not equipped with overflow protection, such as an automatic shut-off device or ball float valve. Owner/operator must notify whoever will fill the tank that automatic shut-off equipment is required on the delivery truck to prevent an overflow and that over filling the tank while under pressure could cause tank failure even if the tank vent is unrestricted. Failure to follow these instructions each time the tank is filled could cause an overflow, over pressurization or tank failure, and could result in death or serious injury.

**TABLE 11-1**

TANK DIA.	INTERIOR DIMENSIONS (mm)					
	"A"	"B"	"C"	"D"	"E"	"F"
1.5	1484	1611	1438	1496	1617	1438
2.4	2362	2489	2316	2355	2482	2304
3.3	3196	3323	3150	3189	3316	3134

**NOTE:** All piping must conform to all applicable codes and standards. See INTRODUCTION.

**WARNING:** When pressure testing the piping, the tank must be isolated from the piping systems. The test pressures for piping may cause the tank to explode and cause death, severe personal injury or property damage.

**CAUTION:** When extending monitoring or vapour recovery piping to the surface, be sure that the at-grade fittings are different from any fittings and will not accept standard fill hoses.

## 12. SUMPS/BOTTOM FITTINGS

If the tank has a sump or a bottom fitting, take extra care that the tank does not rest on it prior to installation.

During installation, provide a clear area in the bedding material, so that the tank rests on the bedding and the sump or bottom fitting is clear. After setting the tank, fill and tamp the resulting void by hand before continuing the backfilling.

## 13. BACKFILLING TO GRADE

When the tank has been set, tested and backfilled, and all piping and venting has been completed, the balance of the backfill material may be added.

When the tank has been backfilled to Sub Grade (before concrete or asphalt), take the final diameter reading (Deflection reading "B" on the checklist).

The same material as specified in Section 3 must be used to completely fill excavation. The backfill must be free of debris. Any blocks or bricks used as support material during piping must be removed prior to completion of backfilling.

Safety measures, such as placing barricades until installation is complete, should be used around the excavation site.

Check and record the level of brine in the monitor fitting. If the level has dropped significantly from the level recorded at the beginning of the installation process, contact FTS immediately.

Be sure that the installation meets all of the requirements of minimum cover as specific in Section 4. Be sure that the checklist is properly completed.

## 14. DEFLECTION MEASUREMENT

Four deflection measurements should be taken:

1. Initial measurement on placement of the tank in the hole (measurement A on the Installation Checklist).
2. An intermediate measurement when straps are tightened to ensure uniform tightening.
3. When backfill to top of tank is completed.
4. At Sub Grade (before concrete or asphalt topping) measurement B on the Installation Checklist.

### DIPSTICK PREPARATION

Drive a small-headed, non-sparking (e.g. Brass) nail halfway into a wooden dipstick 25mm up from its base.

### FIRST DIAMETER READING (PLACEMENT)

1. Place the dipstick into a socket fitting.
2. Measure and record the distance from the tank bottom to the top of the fitting.
3. Pull the dipstick up until the nail catches on the inside top of the tank.
4. Measure the distance from the tank top (inside) to the top of the fitting. Subtract 25mm from this measurement and record the distance.
5. Subtract the second distance from the first and record this value as reading "A" on the Installation Checklist.

### SUB GRADE DIAMETER READING

1. Place the dipstick into a socket fitting with a riser installed to sub-grade.
2. Measure and record the distance from the tank bottom to the top of the standpipe.
3. Pull the dipstick up until the nail catches on the inside top of the tank.
4. Measure the distance from the tank top (inside) to the top of the standpipe. Subtract 25mm from this measurement and record the distance.
5. Subtract the second distance from the first and record this value as reading "B" on the Installation Checklist.

### CALCULATION AND COMPARISON

1. Subtract reading "B" from reading "A".
2. Compare this value to the table of Maximum Allowable Deflections shown on the Installation Checklist.
3. Vertical deflection in excess of these values indicates improper installation and voids the tank warranty.

## 15. MONITORING

### SINGLEWALL TANKS

Single wall tank installations may require release detection monitoring, which can include inventory control, automatic tank gauging, vapour monitoring or ground water monitoring. Check with state and local officials for requirements in your area.

### DOUBLEWALL TANKS

FTS double wall tank has an interstitial space for the containment of leaked product from the primary tank. The tank, as supplied, will have a minimum of one fitting that provides access into the space between the primary (internal) and secondary (external) tank shell walls. If a double wall tank is sloped, the monitor should be at the low end.

### WITH A DRY INTERSTITIAL SPACE

The monitoring system and method is the responsibility of the tank owner and/or operator. A safe electronic or mechanical system should be used to detect either incoming water or product. The monitor system should detect leakage near the bottom of the tank. Monitoring can be done through the access fitting provided. IF the tank is sloped during installation the lowest elevation must be the monitoring end.

### HYDROSTATIC MONITORING SYSTEM

In a liquid filled monitoring system, the interstitial space is filled with liquid at the point of manufacture (except 95000 and larger litre tanks). The system provides continuous leak protection and it enables the owner to conduct a tank tightness test. It also provides the ability to use an electronic monitoring system.

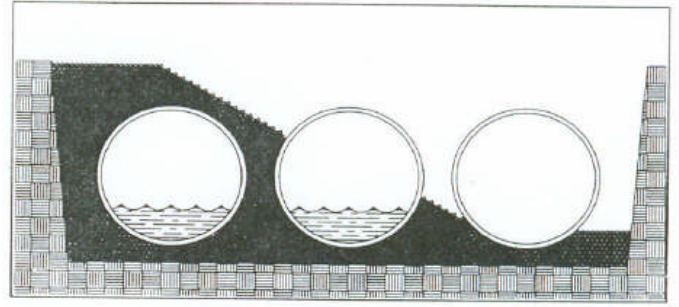

If this method is not practical, additional tanks may be buried in the same installation hole. After emptying existing tanks to less than one-quarter capacity, remove the surface pad.

Enlarge the excavation for the new tank, leaving as much backfill as possible around existing tanks.

It may be necessary to install shoring to make sure that existing tanks do not move and that sufficient backfill remains. The new tanks must be installed by following the procedures in this guide.

Remember to leave minimum of 450mm between tanks. The backfill material must be the same as that specified in Section 3.

## 16. ADDING TANKS AT EXISTING LOCATIONS

Additional FTS tanks can be installed at existing locations if proper foundation support exists. The method of installation is the responsibility of the owner. It is required, however, that one of the following methods be used.

The preferred method is to install a new tank in a separate hole at least 1 Metre from the original hole.

Caution must be exercised in keeping unusual surface loads off existing tanks. The natural barrier of undisturbed soil between tanks must be maintained.

